

(No Model.)

3 Sheets—Sheet 1.

J. L. BOGERT.
CRANK AXLE LATHE.

No. 568,063.

Patented Sept. 22, 1896.

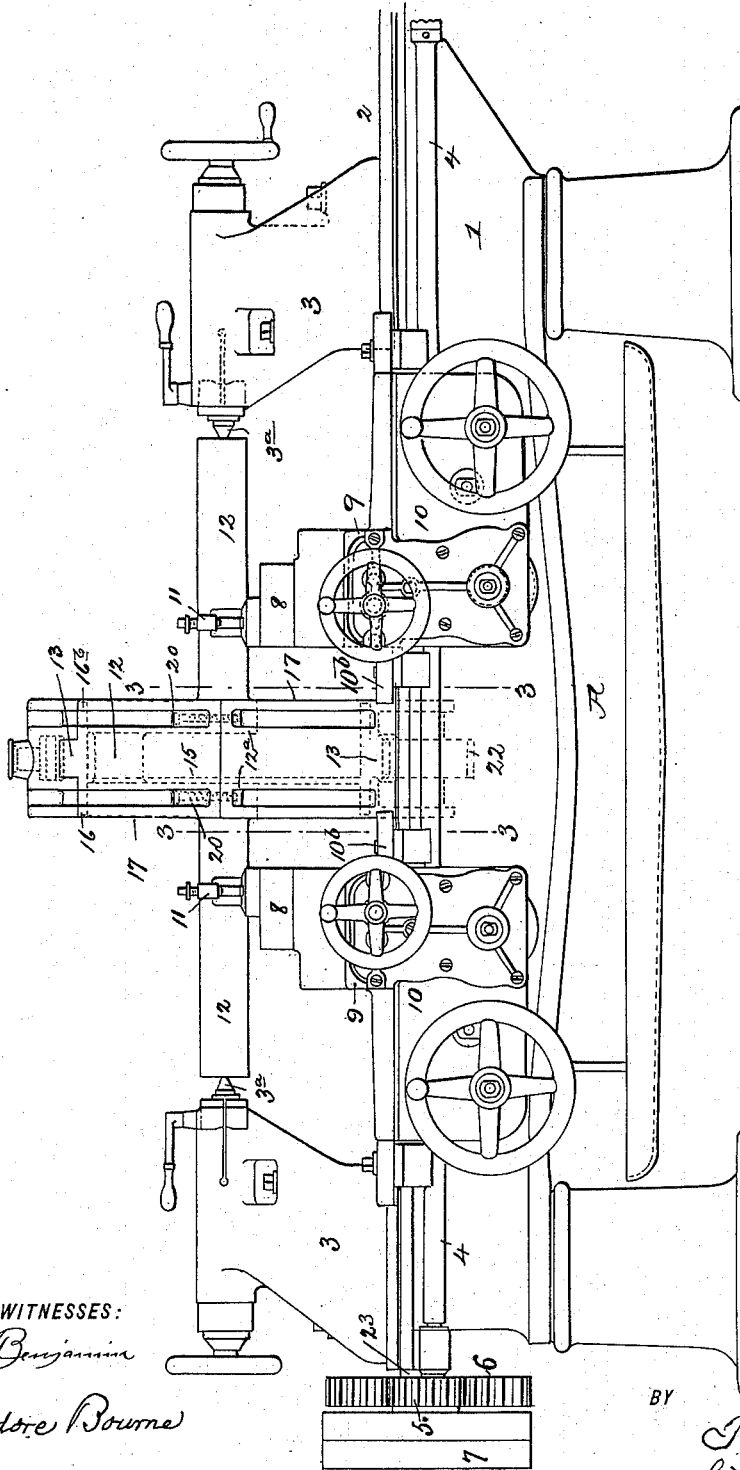

Fig. 1.

WITNESSES:
C. W. Benjamin
Theodore Bourne

INVENTOR
John L. Bogert
BY
T. F. Bourne
his ATTORNEY

(No Model.)

3 Sheets—Sheet 2.

J. L. BOGERT.
CRANK AXLE LATHE.

No. 568,063.

Patented Sept. 22, 1896.

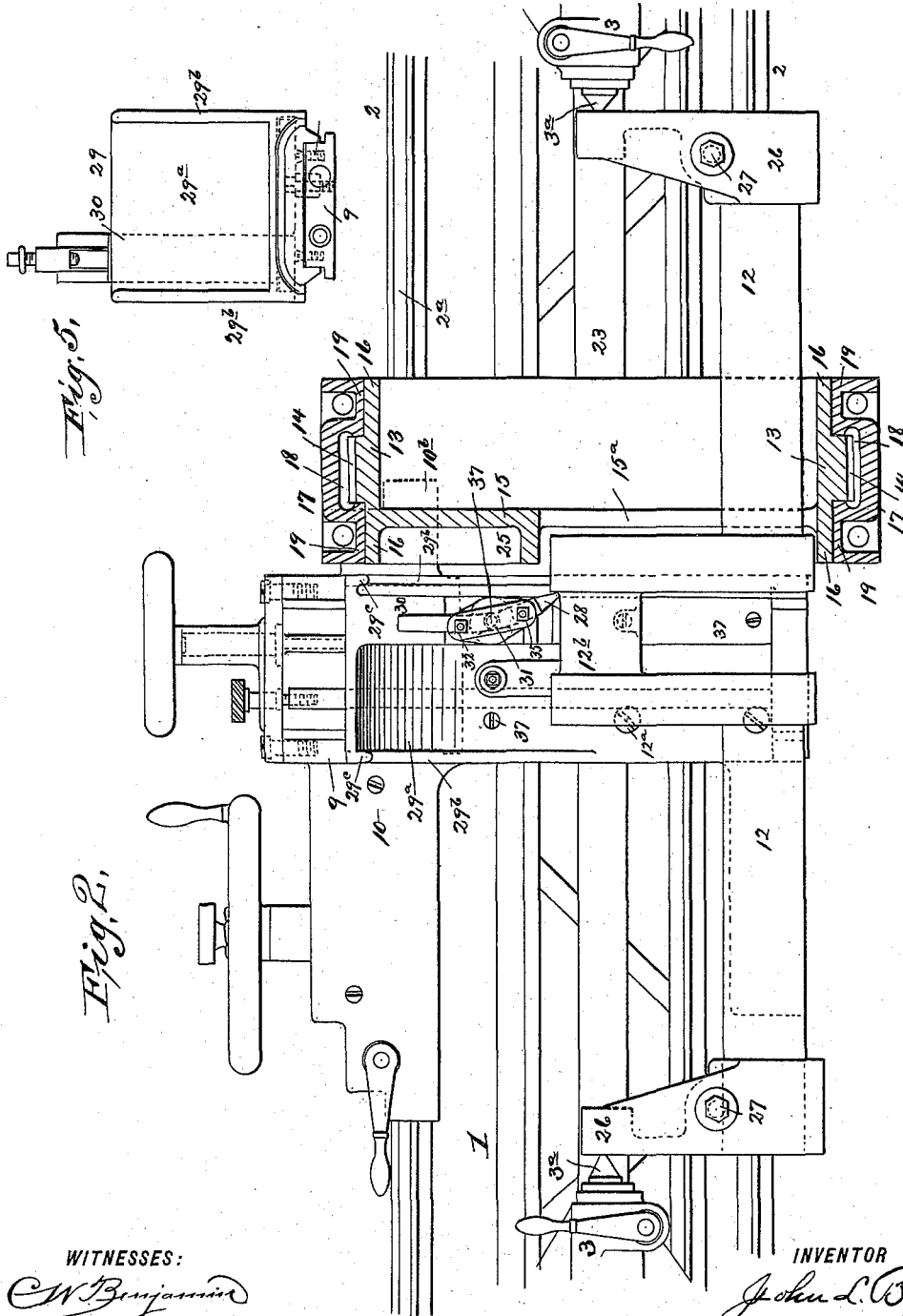

Fig. 1.

Fig. 2.

WITNESSES:

W. Benjamin
Theodore Bourne

INVENTOR

John L. Bogert

BY

T. F. Bourne
his ATTORNEY

(No Model.)

3 Sheets—Sheet 3.

J. L. BOGERT.
CRANK AXLE LATHE.

No. 568,063.

Patented Sept. 22, 1896.

Fig. 3.

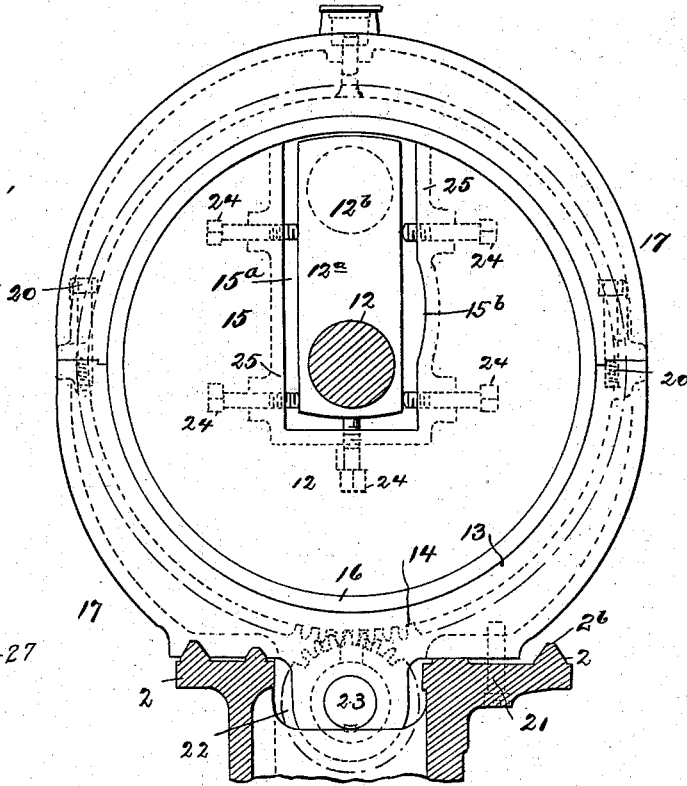

Fig. 6.

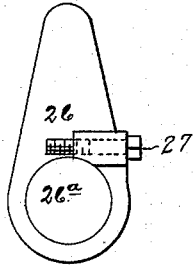
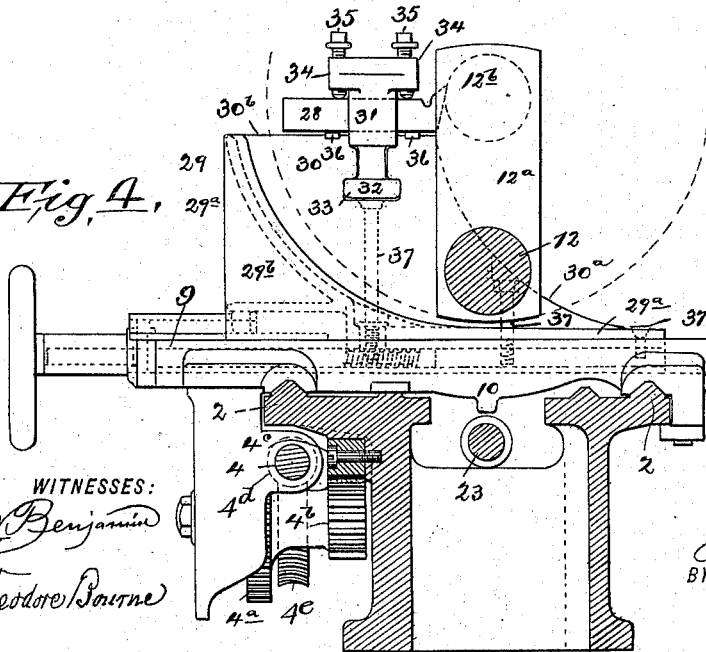

Fig. 4.



WITNESSES:
C. W. Benjamin
Theodore Bourne

INVENTOR
John L. Bogert
BY
T. F. Bourne
his ATTORNEY

UNITED STATES PATENT OFFICE.

JOHN L. BOGERT, OF FLUSHING, NEW YORK.

CRANK-AXLE LATHE.

SPECIFICATION forming part of Letters Patent No. 568,063, dated September 22, 1896.

Application filed June 21, 1895. Serial No. 553,551. (No model.)

To all whom it may concern:

Be it known that I, JOHN L. BOGERT, of Flushing, Queens county, New York, have invented certain new and useful Improvements in Crank-Axle Lathes, of which the following is a specification.

The object of my invention is to provide a lathe or machine wherein the shafts as well as the crank-pin of a crank-axle can be turned to the desired diameter according to which position the axle is placed in the lathe.

A further object of the invention is to provide a novel tool-support so arranged that the tool can be brought close to the crank-pin while being rigidly carried by its support.

The invention consists in a lathe having two tail-stocks to support the ends of an axle and a rotating wheel placed between said tail-stocks and arranged to receive the crank of said axle, so as to cause the latter to rotate for the purpose of turning it to the desired diameter. In this position the axle will be centered on the centers carried by the tail-stocks. The said rotative wheel is so arranged that the crank of the axle to be turned can be reversed in position, that is to say, the crank-pin can be placed in line with the centers of the tail-stocks, and novel dogs are provided for connection with the ends of the axle and with the centers of the tail-stocks for supporting and guiding the axle as it is carried around by said rotating wheel, the crank-pin meanwhile being in position to be acted upon by a tool.

The invention further consists in a tool-support comprising a concaved body or plate having an outwardly-extending web upon which a tool is supported in position to act on the crank-pin as it is rotated by the above-mentioned wheel.

The invention further consists in the novel details of improvement and the combinations of parts that will be more fully hereinafter set forth, and then pointed out in the claims.

Reference is to be had to the accompanying drawings, forming part hereof, wherein—

Figure 1 is a side elevation of my improved lathe, showing the parts in position for turning the main parts or shafts of the crank-axle. Fig. 2 is a partly sectional plan view showing the crank-axle placed in position to have the crank-pin turned. Fig. 3 is a detail cross-

section, enlarged, on the plane of the line 3 3 in Fig. 1, looking from the left in Fig. 1, showing the axle in position to be turned. Fig. 4 is a detail cross-section, enlarged, through the bed, looking from the left in Fig. 2, showing the crank-pin in position to be turned. Fig. 5 is a detail back view, enlarged, of the support for holding the tool that operates on the crank-pin; and Fig. 6 is a detail face view of the dog that connects the axle with the centers of the tail-stock when the crank-pin is to be turned.

In the accompanying drawings, in which similar numerals and letters of reference indicate corresponding parts in the several views, the numeral 1 indicates the bed of the lathe. 2 are the ways, and 3 are the tail-stocks suitably mounted on ways.

8 8 are tool-posts carried by cross-slides 9 9 on carriages 10 10, mounted on the ways 2 for feeding the tools 11 11 to and along the crank-axle 12 to turn the latter to the desired diameter. Said carriages are driven by means of a rod 4, which may be a screw or may carry worms 4^a, engaging with worm-wheels 4^b, which operate gearing 4^a 4^b, the pinion 7^b meshing with a rack 4^c, secured on bed 1, as in Fig. 1. The above-described parts may be of any suitable or desired well-known construction and provided with the necessary feeding-screws, hand-wheels, &c., all of which need not be further described here.

13 is a gear-wheel having peripheral teeth 14 and an internal web or plate 15, and on opposite sides of said web or plate 15 the gear-wheel 13 has circular flanges 16 16. (See Figs. 1 and 2.)

17 is a frame or guide for the gear-wheel 13, which frame or guide has a cylindrical bore in which the wheel 13 rotates. The frame or guide 17 has an internal annular cavity 18, in which the teeth 14 of the gear-wheel 13 travel, and on opposite sides of said cavity 18 the frame 17 has annular surfaces 19 19, forming ways upon which the flanges 16 16 of the gear-wheel 13 rotate and by which said gear-wheel is supported. (See Fig. 2.) The frame 17 is shown made in two halves fastened together by screws 20, whereby the wheel 13 can be inserted in and removed from said frame. The frame 13 may be firmly secured on the bed 1 by screws 21 or otherwise. The

gear-wheel 13 is rotated by a pinion 22, carried by a shaft 23, (see Fig. 3,) that is suitably journaled in bearings in the bed 1, the shaft 23 carrying the gear-wheel 6, that is driven by the pinion 5, connected with pulley 7. It will be understood that this arrangement of driving-gearing may be modified as desired without changing the nature of the invention, as, for example, a worm might be used to engage with the gear-wheel 13, its teeth being suitably shaped to correspond thereto. Thus the gear-wheel 13 can be rotated within the frame 17.

The shaft 12 to be operated upon is a crank-shaft, 12^a being the crank-arms, and 12^b the crank-pin connecting said arms. The web or plate 15 of the wheel 13 is provided with a slot or opening 15^a, through which the axle 12 can pass and within which the crank 12^a can lie. (See Figs. 2 and 3.) The slot or opening 15^a in Fig. 3 is shown elongated and extends outwardly across the center of the web 15, beyond the rim of the wheel, as in Fig. 3. Said slot or opening is also shown substantially rectangular, whereby its side will bear against the crank 12^a, to carry the latter around as the wheel 13 rotates, and thus rotate the axle 12 or crank-pin 12^b, according to which position the axle may be placed in. By preference, however, I provide adjusting and holding screws 24, which are carried by the web 15 and can be pressed against the crank 12^a to hold the latter firmly in position. The screws 24 may be carried by flanges 25, which surround the slot or opening 15^a, as shown, or otherwise. When it is desired to turn the axle 12, the latter is passed through the slot 15^a from one end, so that one crank-arm 12^a will lie in the slot or opening 15^a of the web 15 of wheel 13, the opposite ends of the axle 12 being supported by the centers 3^a of the tail-stocks 3 3. (See Figs. 1 and 2.) In this position when the wheel 13 rotates the cranks 12^a will be carried around with it and thus rotate the axle 12 around the centers 3^a. As the tool-supports 8 8 now travel back and forth along the axle 12 the tools 11 11 will act on said axle in well-known manner to turn it to the desired diameter. Thus the axle on opposite sides of the crank-arms can be turned by the tools simultaneously and quickly.

When it is required to turn the crank-pin 12^b to a desired diameter, the crank is removed from the slot 15^a in the web 15 of the wheel 13 and reinserted in said slot 15^a in the reverse position, that is to say, so that the crank-pin 12^b will be at the center of the wheel 13 and in line with the centers 3^a, (as in Figs. 2 and 4,) the axle 12 thereupon being located near the outer end of the slot 15^a. (See Fig. 4.) In this position only one of the crank-arms 12^a will lie in the slot 15^a, so that the crank-pin 12^b will lie outside of the face of the corresponding rim or flange 16 of the wheel 13. The crank may then be fastened in the slot 15^a. The axle 12 should now be supported and

guided at its ends upon and around the centers 3^a, and for this purpose I provide dogs or arms 26 26, which have apertures 26^a to receive the ends of the axle and means to fasten them to the axle, such as screws 27, tapped into said dogs or arms and bearing against said axle (see Figs. 2, 3, and 6) or otherwise. To permit the screws 27 to pass freely through the slot or opening 15^a when the axle and crank are being adjusted upon the wheel 13, one side of said slot may be widened or hollowed at 15^b. (See Fig. 3.) The opposite ends of the dogs or arms 26 are adapted to be held by the centers 3^a, as in Fig. 2, whereby as the axle 12 is carried around bodily by the wheel 13 it will be guided and supported by the centers 3^a.

When the axle and crank are in the positions above specified, the axis of the crank-pin will be rotated in line with the centers 3^a, so that a tool 28 can operate on said crank-pin to turn it to the desired diameter. Any suitable tool-post may be used for the tool 28, but in order to firmly hold the tool near its cutting end and yet allow it to approach close to the crank-pin 12^b without interfering with the rotation of the parts I have provided the following novel devices: Upon the cross-slide 9, suitably carried on the carriage 10, I secure a tool-support 29, which consists of a concave plate or casting 29^a, which rises up nearly to a level with the crank-pin 12^b and extends forwardly under the same. (See Fig. 4.) 29^b are vertical strengthening-webs at the sides of the plate 29^a, which extend outwardly back of the latter and are also concave on their inner edges, as in Fig. 4. The webs 29^b also extend inwardly of the plate 29^a at 29^c to form a gutter or channel for the drip from the tool 28 to convey the drip to a suitable receptacle A. (See Fig. 1.)

30 is an inner vertical web carried by the plate 29^a, the inner edge of the web 30 being concaved at 30^a, as in Fig. 4. This web 30 is placed at one side of the center of the plate 29^a, as in Figs. 2 and 5, so as to bring the tool 28 as near the wheel 13 as possible. The top 30^b of the web 30 is shown as flat and is elevated to such a height that when the tool 28 is in position it will be properly presented to the crank-pin 12^b, as in Fig. 4. Suitable means may be provided for holding the tool 28 upon the top of the web 30. I have shown a clamp for this purpose consisting of a slotted bar 31, having a head 32 to fit in a recess or socket 33 in the web 30, the bar 31 at its upper end having wings 34 to receive set-screws 35, that bear on the tool 28 to bind it upon the top of web 30 or on blocks 36. By this means the tool 28 is supported close under its cutting edge and the cranks 12^b straddle the web 30 and tool 28 as said cranks rotate. (See Fig. 2.) Screws 37 hold the tool-support above described upon the cross-slide 9, certain of the screws being shown passing through the forward end of plate 29^a. Any well-known or suitable means may be pro-

vided for feeding the cross-slide 9 on the carriage 10 to present the tool 28 to the crank-pin 12^b and for feeding the carriage 10 along the ways 2. The tool 28 in Fig. 2 is shown
 5 curved, so that it can conveniently reach the corners between the crank-pin 12^b and the crank-arms 12^a. If the crank-pin is short, a tool of width corresponding to the length of the crank-pin may be used, in which case the
 10 carriage need not have side movement while turning the crank-pin.

As shown in Fig. 3, the frame 17 is not in contact with one of the ways 2 (as 2^b) and the carriage 10 has an extended way or guide 10^b,
 15 (see dotted lines in Fig. 2,) which enables said carriage 10 to be fed close to the frame 17 and wheel 13 while being properly guided on its ways.

From what has been explained it will be seen that the axle or its crank-pin can be readily turned in the lathe by either placing the axle 12 in line with the axis of the wheel 13 and using the tools 11 11, or by placing the crank-pin 12^b in line with the axis of said
 25 wheel and using tool 28. In both cases the web or plate 15 serves to rotate the axle or its crank-pin in line with the centers 3^a. It will be understood that tool-supports 30 can be used for turning the shaft of the axle, if desired, instead of the ordinary tool-posts 8, one being a substitute for the other; but the tool 11 and post 8 are not adapted for the turning of the crank-pin. It will be seen also that the several parts of the lathe do not
 30 have to be removed to permit of the several operations on the axle or its crank-pin, but merely the position of the axle and its crank in the wheel 13 regulates the work to be done.

Having now described my invention, what I claim is—

1. In a lathe, the combination with the centers and a tool-holding carriage, of a rotative wheel located between said centers and having an aperture to receive the crank of a
 45 crank-axle to cause the latter to rotate, a bearing to sustain said wheel, and mechanism for rotating said wheel, substantially as set forth.

2. In a lathe, the combination of a bed, tail-stocks thereon and tool-supports, with a rotative wheel located between said tail-stocks and having an interior web or plate provided with a slot or opening that extends across the center of said wheel outward toward the rim thereof and devices carried by the wheel arranged to receive the crank of a crank-axle to rotate the axle or the crank-pin in line with the centers of the tail-stocks, a bearing to sustain said wheel, and mechanism for rotating said wheel, substantially as described.
 60

3. In a lathe, the combination of a bed, tail-stocks and tool-supports, with a frame or guide carried by said bed between said tail-stocks, and a rotative wheel having side rims or flanges guided by said frame, and supported by said side rims, said wheel having

an interior web or plate provided with a slot or opening to receive the crank of a crank-axle to rotate the same, substantially as described.
 70

4. In a lathe, the combination of a bed, tail-stocks and tool-supports with a frame having a cylindrical bore and a rotative wheel having peripheral gear-teeth and side rims or flanges to bear on each other and the bore of said frame, said wheel having an opening arranged to receive the crank of a crank-axle, and with a pinion to rotate said wheel, and means to rotate said pinion, substantially as described.
 75

5. In a lathe the combination of a bed, tail-stocks thereon, and tool-support, dog-arms pivotally mounted on the respective tail-stocks that are adapted for holding the ends of a shaft in a raised position and revoluble therewith, with a rotative wheel arranged to receive the shaft of a crank-axle to rotate the crank-pin in line with the centers of the tail-stocks, and means for driving the wheel directly, substantially as described.
 85

6. In a lathe, the combination of a bed, means to support the ends of a crank-axle, with a rotative wheel having an interior web or plate provided with a slot or opening which extends across the center of said wheel outward to near its periphery, said web or plate having webs or flanges around the edges of said slot or opening and screws carried by said webs or flanges to hold a crank in said slot or opening, and means for driving said
 90 wheel directly, substantially as described.

7. In a lathe, a bed and means to support the ends of a crank-axle, with a rotative wheel having an interior web or plate provided with a slot or opening to receive the crank of a
 105 crank-axle, said web or plate being located near one side of said wheel so that one crank-arm of the crank-axle can be held in said slot or opening while the crank-pin projects outwardly beyond the wheel to enable a tool to
 110 operate on it, and means for driving said wheel directly, substantially as described.

8. In a lathe, the combination of a bed, and means to support the ends of a crank-axle with a rotative frame having a cylindrical bore, and an annular cavity 18 therein, with a gear-wheel guided by the bore of said frame to rotate therein, the teeth of said wheel being located in said annular cavity, said wheel having an interior web or plate to provide a
 120 slot or opening to receive the crank of a crank-axle, means for rigidly connecting said wheel with said crank-axle and means for driving said wheel directly to rotate said axle, substantially as described.
 125

9. In a lathe, the combination of a bed and tail-stocks, with a rotative wheel having an interior web or plate provided with a slot or opening to receive the crank of a crank-axle, and with dogs having means to secure them
 130 to said axle, and arranged to engage and rotate around the centers of said tail-stocks,

and means for driving said wheel directly, substantially as described.

10. A tool-support comprising an upwardly-extending gutter-like plate that extends
5 across under the edge of the cutting-tool to receive chips and cutting fluid, substantially as described.

11. A tool-support comprising an upwardly-extending curved plate having side support-
10 ing-webs that extend below the curved plate and an inner web arranged to support a tool, substantially as described.

12. A tool-support comprising a concave gutter-like upwardly-extending plate that
15 extends across under the edge of the cutting-tool to receive chips and cutting fluid, and an inner vertical web arranged to support a tool, substantially as described.

13. A tool-support comprising a concave
20 upwardly-extending plate having side supporting-webs said plate extending across under the edge of the cutting-tool to receive chips and cutting fluid and an inner vertical web which is narrower than said plate and
25 arranged to support a tool, substantially as described.

14. A tool-support comprising an upwardly-extending concave plate and inwardly-extending ledges 29° and an inner vertical web
30 arranged to support a tool, substantially as described.

15. A tool-support comprising an upwardly-extending concave plate that extends across
35 under the edge of the cutting-tool to receive chips and cutting fluid having a vertical inner web to support a tool, said web being located near one side of said plate to enable a

tool to move close to a rotating piece of work, substantially as described.

16. The combination of a bed, means to
40 support the ends of a crank-axle and a rotative wheel arranged to drive the crank of a crank-axle so that the crank-pin can rotate on its axis, with a tool-support having a vertical web arranged to hold a tool and adapted
45 to permit said crank to straddle it while the crank is carried around, substantially as described.

17. The combination of a bed having ways,
50 and means to support the ends of a crank-axle, with a frame carried by said bed and so arranged that one of said ways 2^b will be entirely free, with a carriage mounted on said ways, said carriage having an extended arm
55 10^b to travel on said way 2^b under the said frame to guide said carriage close to said frame, substantially as described.

18. The combination of a bed, a carriage and cross-slide, and a feed-screw, with a tool-
60 support consisting of a concave plate and upwardly-extending web, said plate being carried forward under the cutting edge of a tool and above the feed-screw, so as to protect said screw and bearing-surfaces of the cross-
65 slide from the chips that fall from the work, substantially as described.

Signed at New York, in the county of New York and State of New York, this 19th day of June, A. D. 1895.

JOHN L. BOGERT.

Witnesses:

T. F. BOURNE,
P. MILES.